

Schnellschlussventil PN 40

Edelstahl, Durchgangsform
 federbelastet, kompakte Bauweise

- Flanschbohrungen nach DIN EN 1092-1 PN 40
- Verwendung: Verschiedene Arten von Flüssigkeiten, wie z.B. Heiz-, Diesel-, Schweröl und Wasser
- Betätigungsarten:
 Manuell am Ventil,
 fernbedient hydraulisch und pneumatisch

Quick-closing Valve PN 40

stainless steel, straight pattern
 spring-loaded, compact design

- flange drilling acc. to DIN EN 1092-1 PN 40
- application: for different kind of liquids, mainly fuel oil, diesel oil, heating oil and water
- operation mode:
 locally manual operation,
 remotely controlled hydraulically and pneumatically

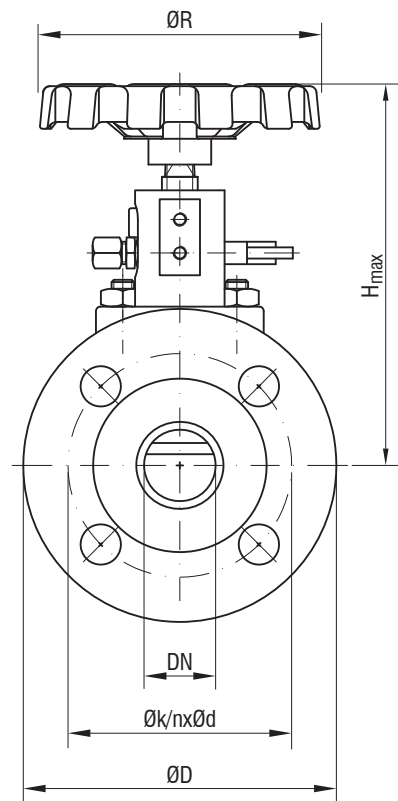
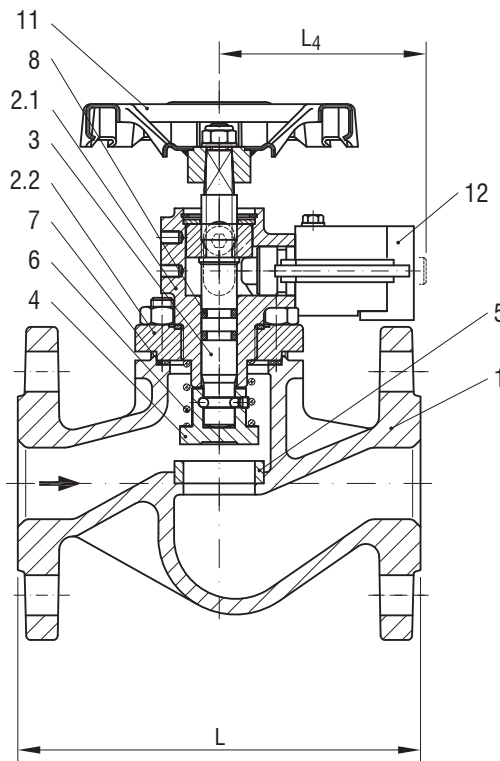

Pos. item	Bezeichnung denomination	AW 33614		Pos. item	Bezeichnung denomination	AW 33614	
1	Gehäuse / body	GX5CrNiMo19-11-2	1.4408	6	Feder / spring	X10CrNi18-8	1.4310
2.1	Hülse / sleeve	X5CrNi18-10	1.4301	7	Dichtung / gasket	Novapress Universal	
2.2	Deckel / cover	GX5CrNiMo19-11-2	1.4408	8	O-Ring / O-ring	FPM (Viton)	
3*	Spindel / stem	X8CrNiS18-9	1.4305	11	Handrad / hand wheel	St	
4*	Kegel / disc	X8CrNiS18-9	1.4305	12	Auslöser / actuator	9SMn28K	1.0715
5	Sitzring / seat bush	GX5CrNiMo19-11-2	1.4408				

DN	L	H _{max}	l ₄	ØD	ØR	Øk	n	Ød	≈kg
15	130	165	93	95	125	65	4	14	4,7
20	150	165	93	105	125	75	4	14	5,5
25	160	175	93	115	125	85	4	14	6,6
32	180	175	93	140	125	100	4	18	7,7
40	200	190	93	150	125	110	4	18	9,9
50	230	190	93	165	125	125	4	18	12,7

*: auch in 1.4571 erhältlich
 also available out of 1.4571

AW	DN	Betriebsdruck working pressure max.	Temperatur temperature max.
33614	15 - 50	35 bar	140°C

ACHTUNG: Es gelten Einschränkungen bei Installation auf der Druckseite einer Pumpe! Bitte Rücksprache mit ARMATUREN-WOLFF.
 ATTENTION: On the pressure side of a pump restrictions apply! Please contact ARMATUREN-WOLFF for technical advice.