

Absperrschieber PN 16

Rotguss/Messing

nichtsteigende Spindel, eingeschraubtes Oberteil

- Flanschbohrungen nach DIN EN 1092-3 PN 16

Gate Valve Flat Body PN 16

gunmetal/brass

non rising stem, screwed-in bonnet

- flange drilling acc. to DIN EN 1092-3 PN 16

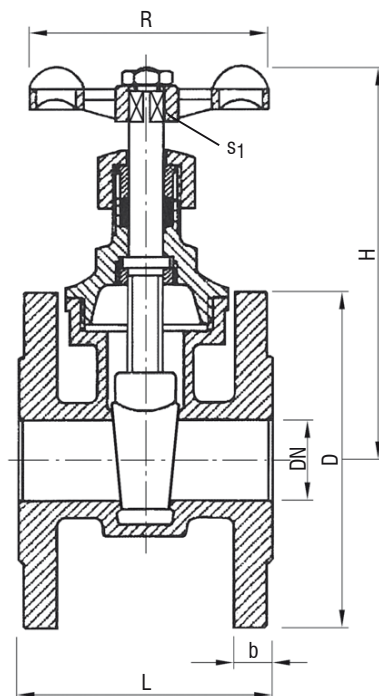

AW-Nr. AW no.	Pos. item	Bezeichnung denomination	Werkstoff material	nach DIN EN acc. to DIN EN	Werkstoff-Nr. material no.
108	1	Gehäuse / body	Rotguss / gunmetal	G-CuSn5ZnPb5-C	CC491K
	2	Oberteil / bonnet	Messing / brass	CuZn39Pb3	CW614N
	3	Spindel / stem	Messing / brass	CuZn39Pb3	CW614N
	4	Keil / wedge	Rotguss / gunmetal	G-CuSn5ZnPb5-C	CC491K
	5	Handrad / handwheel	Alu-Druckguss / alu die casting		

DN	L	H	R	D	b	s ₁	≈ kg
20	75	105	70	105	12	7	1,8
25	80	115	70	115	12	8	2,3
32	90	130	80	140	14	9	3,6
40	100	150	90	150	14	9	4,6
50	110	180	110	165	16	11	6,4
65	130	220	150	185	16	12	9,4
80	150	250	160	200	18	13	12,1

Verwendung:

Für nichtbrennbare, ungiftige Flüssigkeiten, Gase und Dämpfe

Application:

Suitable for non-toxic, non-inflammable fluids, gases and vapours

Temperatur / temperature	max Druck / max. pressure
-10°C - 120°C	16 bar
-10°C - 150°C	10 bar
-10°C - 200°C	6 bar