

Schmutzfänger PN 16/25

Sphäroguss
Schrägsitzform

- Flanschbohrungen nach DIN EN 1092-2
- Baulänge nach EN 558-1 Reihe 1

Strainer 16/25

nodular cast iron
Y-type

- flange drilling acc. to DIN EN 1092-2
- face to face acc. to EN 558-1 serie 1

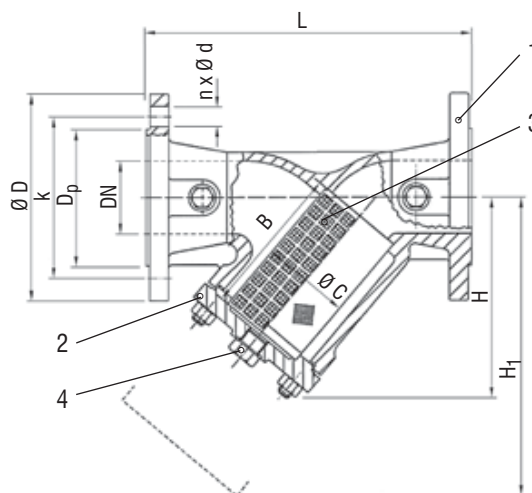

AW-Nr. AW no.	Pos. item	Bezeichnung denomination	Werkstoff material	nach DIN EN acc. to DIN EN	Werkstoff-Nr. material no.
648	1	Gehäuse / body	Sphäroguss / nodular cast iron	EN-GJS-400-18U-LT	EN-JS1049
	2	Deckel / bonnet	Sphäroguss / nodular cast iron	EN-GJS-400-18U-LT	EN-JS1049
	3	Sieb / screen	Edelstahl / stainless steel	X5CrNi18-10	1.4301
	4	Entleerungsschraube / drain plug	Stahl / steel		
	5	Dichtung / sealing	CrNiSt-Graphit		

DN	Maschenweite mesh size	PN 16						PN 25										
		L	H	H1	B	Ø C	Ø D	Dp	Ø k	n x	Ø d	≈ kg	Ø D	Dp	Ø k	n x	Ø d	≈ kg
15	1,0	130	90	135	56	23	95	46	65	4	14	2,6	95	46	65	4	14	2,6
20	1,0	150	100	150	68	28	105	56	75	4	14	3,0	105	56	75	4	14	3,0
25	1,0	160	115	180	82	36	115	65	85	4	14	4,3	115	65	85	4	14	4,3
32	1,0	180	135	215	98	42	140	76	100	4	19	6,8	140	76	100	4	19	6,8
40	1,0	200	150	240	114	50	150	84	110	4	19	8,8	150	84	110	4	19	9,0
50	1,0	230	160	250	119	61,5	165	99	125	4	19	11,0	165	99	125	4	19	11,0
65	1,25	290	180	285	134	78,5	185	118	145	4	19	16,8	185	118	145	8	19	16,8
80	1,25	310	215	330	149	89,5	200	132	160	8	19	19,5	200	132	160	8	19	19,5
100	1,6	350	235	365	169	109,5	220	156	180	8	19	29,6	235	156	190	8	23	29,6
125	1,6	400	280	425	199	137,5	250	184	210	8	19	42,5	270	184	220	8	28	42,5
150	1,6	480	320	480	224	160	285	211	240	8	23	49,0	300	211	250	8	28	56,0
200	1,6	600	405	610	284	210	340	266	295	12	23	98,0	360	274	310	12	28	110,0

Auf Anfrage / on request

- Gewindebohrungen für Differenzdruckanzeige
female thread for differential pressure indicator
- Magneteinsatz
magnetic cartridge
- andere Maschenweiten
other mesh sizes

zulässige Betriebstemperaturen und -drücke admissible temperatures and pressures

	-10°C	120°C	250°C	350°C
PN 16	16 bar	16 bar	13,9 bar	11,2 bar
PN 25	25 bar	25 bar	21,8 bar	17,5 bar

Maße und Gewichte können je nach Hersteller abweichen / depending on manufacturers measures and weight can change