

Einfachfilter PN 10/16

Sphäroguss
 Bügel-Schnellverschluss
 oder Deckel mit Schrauben

- Whitworth Rohrringengewinde G 1/2" bis G 2"
- Filterfeinheit: 10 - 5.000 µm (5 mm)

Single Filter PN 10/16

nodular cast iron
 clamp quick fastener
 or screwed cover

- Whitworth female thread G 1/2" up to G 2"
- filter mesh: 10 - 5.000 µm (5 mm)

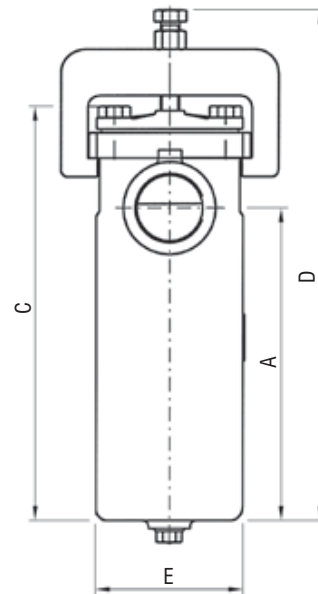
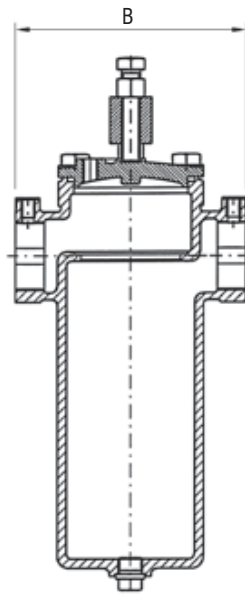

AW-Nr. AW no.	Pos. item	Bezeichnung denomination	Werkstoff material	nach DIN EN acc. to DIN EN	Werkstoff-Nr. material no.
610	1	Gehäuse / body	Sphäroguss / nodular cast iron	EN-GJS-500-7	EN-JS1050
	2	Deckel, Bügel / cover, clamp	Sphäroguss / nodular cast iron	EN-GJS-500-7	EN-JS1050
	3	Sieb / screen	Edelstahl / stainless steel	X5CrNi18-10 / X5CrNiMo17-12-2	1.4301 / 1.4401
	4	Dichtung / seal	NBR		

G	Bügel / clamp	PN Schrauben / screws	E	A	B	C Schrauben / screws	D Bügel / clamp	Durchfluss / flow bei / at 2,5 m/s m ³ /h	Inhalt / content l	Filterfläche / filter surface cm ²	≈ kg
1/2"	10	16	127	270	200	345	405	1,1	3	500	12
3/4"	10	16	127	270	200	345	405	2,5	3	500	12
1"	10	16	127	270	200	345	405	4,5	3	500	12
1 1/4"	10	16	127	270	200	345	405	7,1	3	500	12
1 1/2"	10	16	127	270	200	345	405	10	3	500	12
2"	10	16	127	270	200	345	405	18	3	500	12

Maße und Gewichte können je nach Hersteller abweichen / depending on manufacturers measures and weight can change